

PowerTech 6135SFM Diesel Engine

Propulsion Engine Specifications

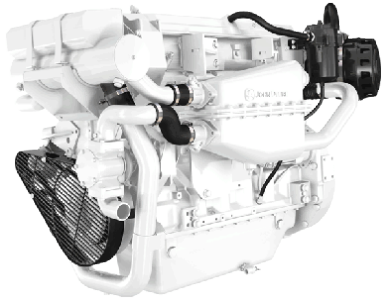

6135SFM shown

Dimensions

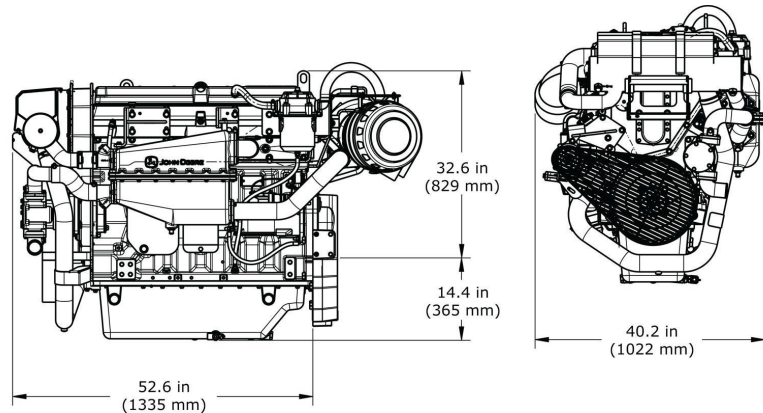

Certifications

- IMO MARPOL Annex VI
- IWT (2004/26/EC)
- RCD (2003/44/EC)
- US EPA Marine Tier 2 Compliant

General data

Model	6135SFM75	Length - mm (in)	1335 (52.6)
Number of cylinders	6	Width - mm (in)	1022 (40.2)
Displacement - L (cu in)	13.5 (824)	Height, Centerline to Top-- mm. (in)	829 (32.6)
Bore and Stroke-- mm (in)	132 x 165 (5.20 x 6.50)	Height, Centerline to Bottom-- mm. (in)	365 (14.4)
Compression Ratio	16.0 : 1	Weight, dry-- kg (lb)	1525 (3362)
Engine Type	In-line, 4-Cycle	Maximum Installed Angle	Front Up – degrees 12 Front Down – degrees 0
Aspiration	Air-to-sea water		

Features and benefits

Watercooled Turbocharger and Exhaust Manifold

- Cooler and quieter environment for vessel and crew
- Reduced external connections eliminates hoses and fittings that can leak or break

Directed Top-liner Cooling

- Reduces upper liner temperature by as much as 130 degrees Fahrenheit
- Durable and reliable power cylinder components

Replaceable Wet-type Cylinder Liners

- Hardened and precision machined for long life

Heat Exchanger

- High-capacity heat exchanger designed for reliable operation in adverse conditions

High Torque and Low Rated RPM

- Excellent vessel control and maneuvering
- Lower rated rpm limits vibration and noise for better crew comfort

Fuel System

- Electronically controlled unit injectors provide precise fuel delivery with variable timing resulting in excellent fuel economy and excellent performance
- Self diagnostics and protection

Performance curve

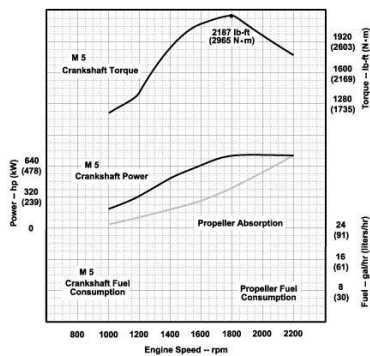
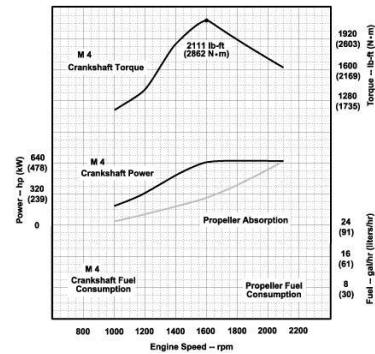
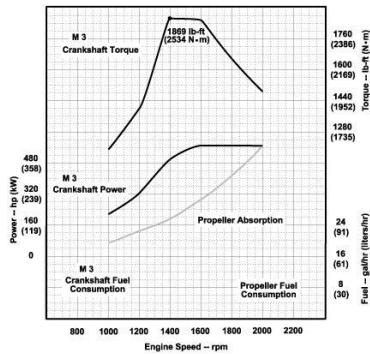
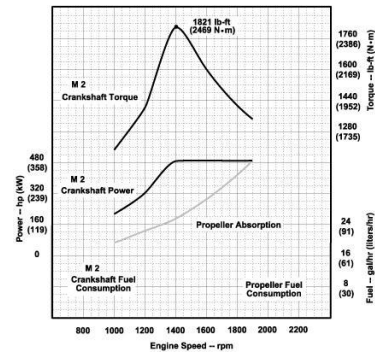
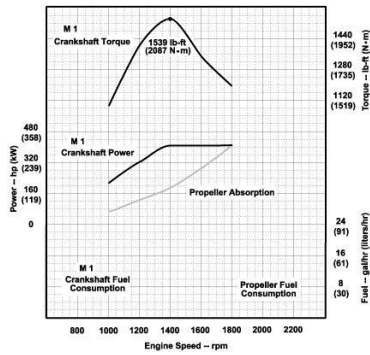

Performance data	M5	M4	M3	M2	M1
Rated Power - kW (hp)	559 (750)	485 (650)	429 (575)	373 (500)	317 (425)
Rated Speed - rpm	2200	2100	2000	1900	1800
Low Idle Speed - rpm	600	600	600	600	600
Peak Torque - Nm (ft-lb)	2895 (2135)	2864 (2112)	2707 (1997)	2544 (1876)	2322 (1713)
Peak Torque Speed - rpm	1700	1600	1500	1400	1300
Fuel Consumption - L/h (gal/hr)	142.9 (37.7)	124.1 (32.8)	108.2 (28.6)	92.9 (24.5)	79.2 (20.9)

M rating	M5	M4	M3	M2	M1
Typical load factor	35 %	40 %	50 %	65 %	> 65 %
Typical annual usage (hr)	300	800	2000	3000	> 3000
Typical full-power operation (hr)	0.5 of each 8	1 of each 12	4 of each 12	16 of each 24	24 Uninterrupted

John Deere Power Systems
3801 W. Ridgeway Ave.
PO Box 5100
Waterloo, IA 50704-5100
Phone: 1-800-533-6446
Fax: 319.292.5075

John Deere Power Systems
Usine de Saran
La Foulonnerie - B.P. 11.13
45401 Fleury les Aubrais Cedex
France
Phone: 33.2.38.82.61.19
Fax: 33.2.38.82.60.00

Preliminary Information
All values at rated speed and power with standard options unless otherwise noted.
Specifications and design subject to change without notice.